

## Portable pressure calibrator Model CPH7600

WIKA data sheet CT 17.01



### Wally Box III

#### Applications

- Calibration service companies and service industry
- Measurement and control laboratories
- Quality assurance

#### Special features

- Measurement and electrical pressure generation at the touch of a button with integrated pump, from -0.8 ... +20 bar
- Accuracy: 0.025 % of reading  $\pm 0.01$  % FS (incl. calibration certificate)
- Generation/measurement of 4 ... 20 mA, and DC 24 V voltage supply to power transmitters
- Pressure supply via external compressed air line
- Robust case design, IP 67

**Wally Box III, model CPH7600**

## Description

### General information

With the model CPH7600, Wally Box III, WIKA offers a further development of the well-known Wally Box I and Wally Box II. The Wally Box III is a compact, portable pressure calibrator, which has been designed for mobile use as well as for stationary workshop and laboratory testing. A special feature of this test instrument is that it is fitted with two independently-operating pressure systems.

One pneumatic system is designed to be supplied from an external pressure supply, while the supply pressure of the second system is generated by the integrated electrical pressure generation. This enables the user to perform different measurement tasks or calibrations, regardless of external pressure and power supplies.

### Accuracy

The Wally Box III provides an accuracy of 0.025 % of reading  $\pm 0.01$  % FS for the built-in pressure sensor. The temperature compensation of the built-in sensor safeguards the accuracy

for applications in the field. Readings can be displayed in one of 13 standard units.

### Features

With the Wally Box III, not only accurate pressure measurements are possible, but also exact current and voltage measurements, as well as a DC 24 V supply for test items. Pressure values and electrical measured values are simultaneously shown in the display.

The calibrator is integrated into a robust, as well as dust and watertight transport case. Thus the mobile pressure calibrator is particularly suited to use in harsh industrial environments. A flow diagram on the front panel gives information on the connection of the individual pneumatic components. With the built-in NiMH rechargeable battery, a battery life of 50 hours or 125 pump cycles up to 20 bar is guaranteed. The external universal power supply is designed for an operating voltage of AC 100 ... 240 V.

**Software**

The WIKA-CAL calibration software is available for online calibration in combination with a PC. Using this software, the data is automatically transferred into a printable calibration certificate. Furthermore, WIKA-CAL also offers, over and above PC-supported calibration, the management of the calibration and instrument data in an SQL database. For data transfer, an RS-232 interface is available.

**Certified accuracy**

For the CPH7600, the accuracy is certified by a factory calibration certificate which accompanies the instrument. On request, we can provide a DKD/DAkkS calibration certificate for this instrument.

## Specifications

### Model CPH7600

#### Measuring ranges

**Pressure**

Relative pressure	-0.8 ... +20 bar
Overpressure limit	40 bar <sup>1)</sup>
Burst pressure	135 bar <sup>1)</sup>
Accuracy	0.025 % of reading ±0.01 % FS
Resolution	5-digit
Temperature compensation	15 ... 35 °C
Temperature coefficient	0.002 % of the span/°C beyond the 15 ... 35 °C

**Current**

Measuring range	0 ... 24 mA (max. load 1,000 Ω)
Resolution	1 µA
Accuracy	0.015 % of reading ±2 µA (simulation and measurement)

**Voltage**

Measuring range	DC 0 ... 30 V
Resolution	1 mV
Accuracy	0.015 % of reading ±2 mV (measurement)

1) Maximum pressure for the integrated lines: 40 bar

#### Base instrument

Pressure supply	maximum pressure for the integrated pressure generation: 20 bar maximum pressure via external pressure supply: 7 bar
Pressure connection	½ NPT (female)
Permissible media	clean, dry, non-corrosive gases, compatible with silicon, Pyrex, RTV, gold, ceramic, nickel and aluminium

**Output**

Voltage supply	DC 24 V
----------------	---------

**Power supply**

Battery type	DC 16 V, NiMH rechargeable battery
Battery life (fully-charged)	approx. 50 hours (only measurement or with external pressure supply) 125 pump cycles to 20 bar 300 pump cycles to 10 bar 1,000 pump cycles to 2 bar

**Permissible ambient conditions**

Operating temperature	-10 ... +50 °C
Storage temperature	-20 ... +60 °C
Relative humidity	35 ... 85 % r. h. (no condensation)

**Communication**

Interface	RS-232 via special interface cable
-----------	------------------------------------

**Case****Material**

Case	NK-7TM Resin
Front panel	Aluminium
Ingress protection	IP 67 (case closed) IP 40 (case opened)
Dimensions	387.4 x 304.8 x 177.8 mm (15.25 x 12 x 7")
Weight	approx. 7 kg (15.5 lbs.)

**EC conformity, Approvals and certificates****EC conformity**

EMC directive	2004/108/EC, EN 61326 emission (group 1, class B) and interference immunity (portable equipment)
---------------	--

**Approvals**

GOST-R	Import certificate, Russia
--------	----------------------------

**Certification**

Calibration	Standard: 3.1 calibration certificate per DIN EN 10204 Option: DKD/DAkkS calibration certificate
Recommended calibration interval	1 year (dependent on conditions of use)

Approvals and certificates, see website

**Available pressure range and resolution****Pressure range and factors**

	Relative pressure	-0.8 ... +20 bar
	Overpressure limit	40 bar
	Burst pressure	135 bar
Unit	Conversion factor	
psi	1	300.00
bar	0.06894757	20.684
mbar	68.94757	20,684
kPa	6.894757	2,068.4
MPa	0.00689476	2.0684
kg/cm <sup>2</sup>	0.07030697	21.092
cmH <sub>2</sub> O (4 °C)	70.3089	21,093
cmH <sub>2</sub> O (20 °C)	70.4336	21,130
inH <sub>2</sub> O (4 °C)	27.68067	8,304.2
inH <sub>2</sub> O (20 °C)	27.72977	8,318.9
inH <sub>2</sub> O (60 °F)	27.70759	8,312.3
mmHg (0 °C)	51.71508	15,515
inHg (0 °C)	2.03602	610.81

## Features

### Pressure supply

The Wally Box III enables the supply of pressure in two different ways. The first is an integrated electric pump from -0.8 ... +20 bar. The second possibility is the connection of compressed air up to 8 bar, which allows the user to control pressures up to 7 bar via a fine adjustment.

The advantage for the user of these two different pressure supplies is that the compressed air supply of a workshop can be used, but also, for applications in the field, the air supply is ensured via the integrated electrical pressure generation.

### Current and voltage

In addition to pressure, the Wally Box III measures and simulates also a 4 ... 20 mA current loop signals, can measure up to DC 30 V and comes with an internal DC 24 V voltage supply to power the transmitter being calibrated. The DC 24 V voltage supply is switchable for transmitters with mA as well as V output signal.

### Display

The Wally Box III can display up to three calibration values simultaneously. This means that the internal pressure sensor, an external pressure sensor and electrical values (mA or V) can be displayed simultaneously. The instrument has a large graphic LCD display with backlighting.

### Pressure ranges

The Wally Box III features an integrated reference pressure sensor with a measuring range of -0.8 ... +20 bar. Since the accuracy is specified in % of reading, the Wally Box III lends itself to the calibration of test items with different measuring ranges up to 20 bar.

Each pressure range can be accurately generated with the integrated electric pump at the touch of a button, or accurately controlled with external compressed air. The fine adjustment is made with the integrated volume slide.

### Functions

The Wally Box III has a complete range of useful functions. Switch tests can be performed via the internal or external pressure input. The deviation of the test item is directly calculated and indicated on the display. A damping function is available. Up to five frequently-used instrument settings can be stored and retrieved with the touch of a key. Similarly, high-accuracy model CPT6100 external pressure sensors can be connected via a sensor cable. This allows accuracies of up to 0.01 % to be achieved.

### Robustness

The Wally Box III consists of a calibrator, which is built into a rugged service case. With this design, the Wally Box III is suited to extremely harsh operating conditions.

## Display layout

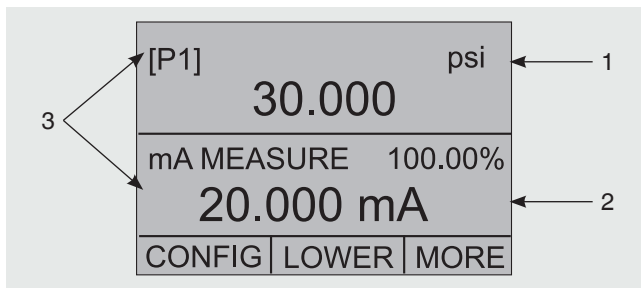

- 1) **Pressure units**  
Indication of the pressure unit (selectable from 13 pressure units)
- 2) **Display of the span**  
Indication of 4 ... 20 mA span (only for the functions mA and mA current loop)
- 3) **Primary parameters**  
Indication of the current measured parameters

## Keypad

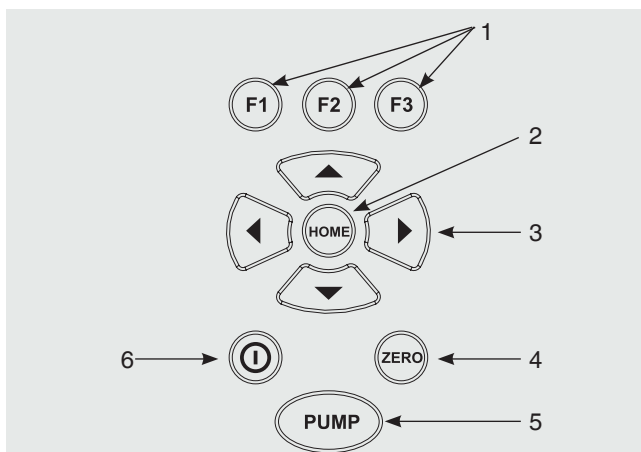

- 1) **Function keys**  
Configuration of the calibrator
- 2) **HOME key**  
Return to main menu
- 3) **Arrow keys**  
Control of the current source/current simulation and adjustment of the pump limit and the %-error limit
- 4) **ZERO key**  
Zeroing of the pressure measurement
- 5) **PUMP key**  
Start-up of the pump operating
- 6) **ON/OFF key**  
Turning the calibrator on and off

Dimensions in mm (inch)

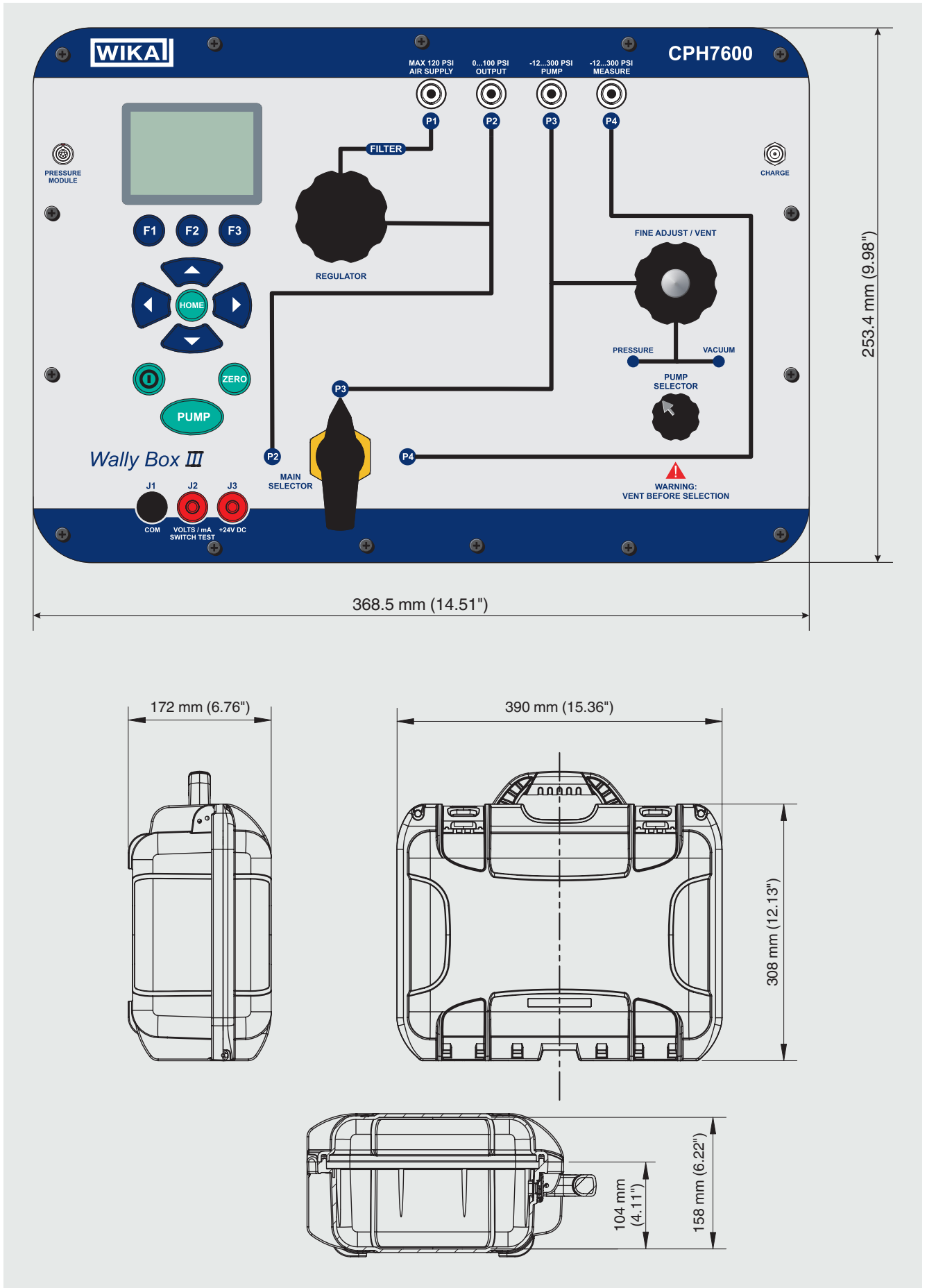

## Special operating modes

### Operating mode: Pressure switch test

#### Pressure switch test

With the pressure switch function, the Wally Box III can indicate the pressures at which the switch closes or opens. In addition, the hysteresis can be calculated.

In the switch test mode the display update rate is increased to capture changing pressure inputs quickly.

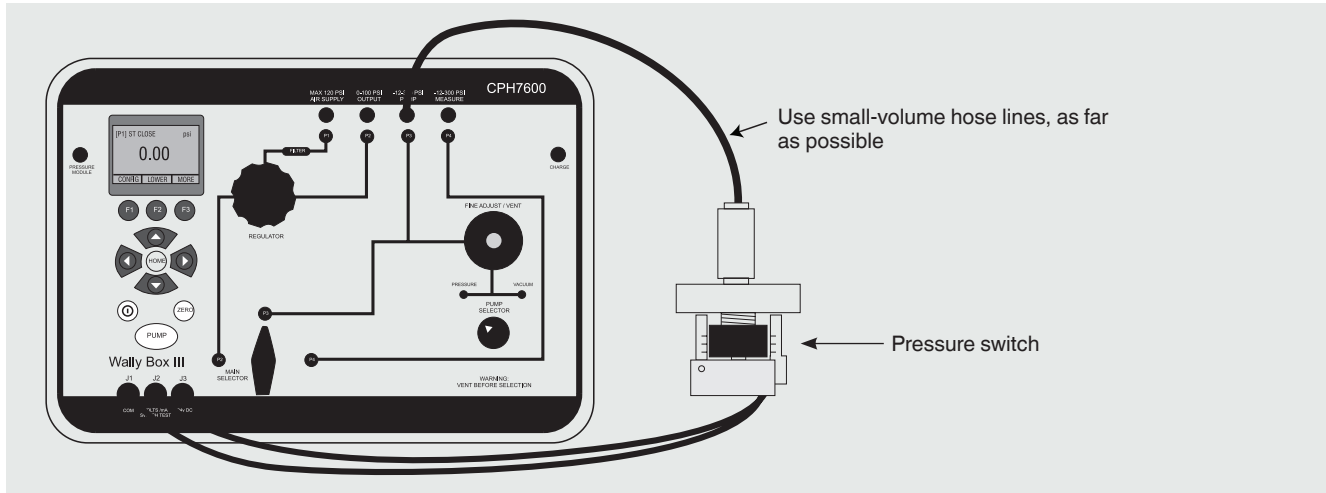

### Operating mode: Calibrating transmitters and %-error function

#### Calibrating transmitters

With the mA/V measuring function, 4 ... 20 mA output and 0 ... 30 V output can be read from the test item. This can be done in two ways.

- 1) **Passively** – the test item generates 4 ... 20 mA or 0 ... 30 V directly. The value is read by the calibrator.
- 2) **Actively** – the calibrator supplies a voltage of DC 24 V to the test item whilst reading the resulting 4 ... 20 mA or 0 ... 30 V signal.

all three screens and has a special menu structure. It displays pressure, mA and %-error simultaneously.

#### Example:

A transmitter to be tested has a measuring range of 20 bar and outputs a corresponding 4 ... 20 mA signal. The user can program in a 0 ... 20 bar pressure span into the calibrator and the calibrator will then calculate and display the deviation or error in a percentage value of the 4 ... 20 mA output. This is produced without the need for any manual calculation, which is also an advantage if it is difficult to set an accurate pressure using an external pump.

The calibrator features a special function which can calculate the error in the pressure value from the mA value as a percentage of the 4 ... 20 mA span. The %-error mode uses

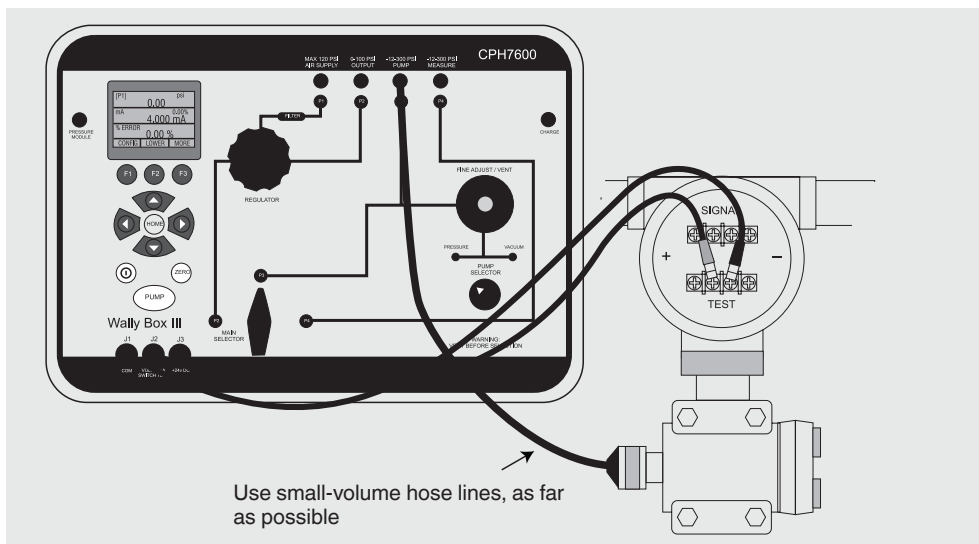

## Dirt trap

The Wally Box III should only be used with dry and clean test items. Soiling of the integrated pump, for example, through contaminated test items, can lead to faults on the pump or require the pump to be cleaned.

By using the dirt trap specifically developed for the Wally Box III, contamination of the integrated pump can be prevented.

## Using the dirt trap

The dirt trap is attached, hand-tight, at the pressure connection of the calibrator. Sealing is achieved via the O-ring fitted on the 1/8 NPT male thread of the dirt trap. The maximum working pressure is limited to 35 bar.

The test item is mounted to the upper connection of the dirt trap, using a suitable sealing method. The connection to the test item is usable universally as 1/8 NPT female or 1/8 BSP female. Use a 7/8" or 23 mm spanner on the hex of the upper pressure port to connect the test item with the dirt trap.

As soon as either moisture or dirt can be seen in the transparent chamber, the dirt trap should be removed and cleaned.

Once the upper dirt trap connection has been unscrewed, the transparent acrylic chamber and the O-rings can be removed and cleaned with a clean cloth.



Wally Box III, model CPH7600 with mounted dirt trap



Dirt trap

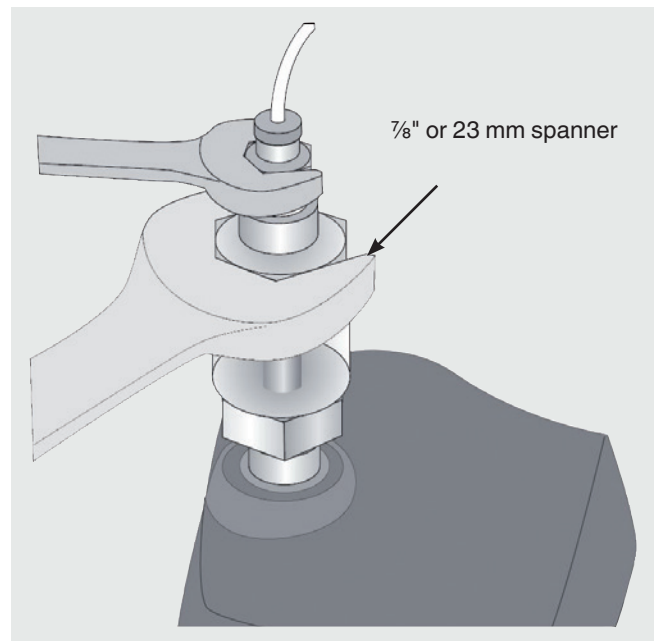
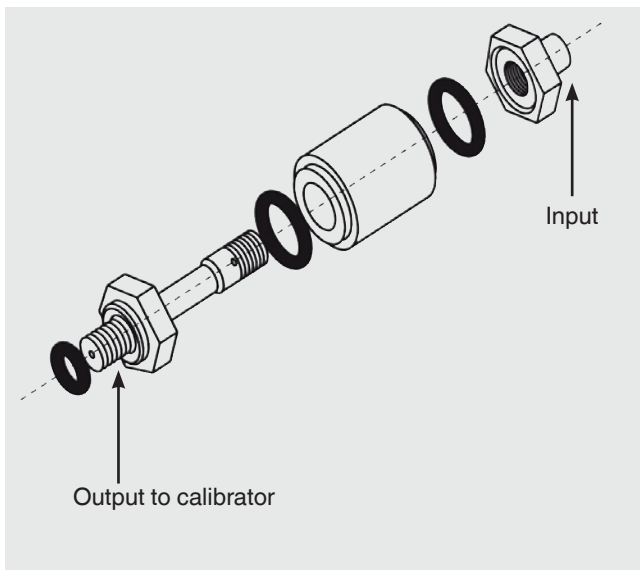

## WIKA-CAL calibration software

### Easy and fast creation of a high-quality calibration certificate

The WIKA-CAL calibration software is used for generating calibration certificates or logger protocols for pressure measuring instruments and is available as a demo version for a cost-free download.

A template helps the user and guides him through the creation process of a document.

In order to switch from the demo version to a full version of the respective template, a USB key with the template has to be purchased.

The pre-installed demo version automatically changes to the selected full version when the USB key is inserted and is available as long as the USB key is connected to the computer.



- Creation of calibration certificates for mechanical and electronic pressure measuring instruments
- A calibration assistant guides you through the calibration
- Automatic generation of the calibration steps
- Generation of 3.1 certificates in accordance with DIN EN 10204
- Creation of logger protocols
- User-friendly interface
- Languages: German, English, Italian and more due with software updates

For further information see data sheet CT 95.10

Calibration certificates can be created with the Cal-Template and logger protocols can be created with the Log-Template.



#### Cal Demo

Generation of calibration certificates limited to 2 measuring points, with automatic initiation of pressures via a pressure controller.



#### Cal Light

Generation of calibration certificates with no limitations on measuring points, without automatic initiation of pressures via a pressure controller.

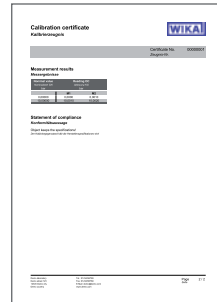
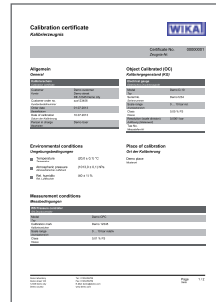

#### Log Demo

Creation of data logger test reports, limited to 5 measured values.



#### Log

Creation of data logger test reports without limiting the measured values.

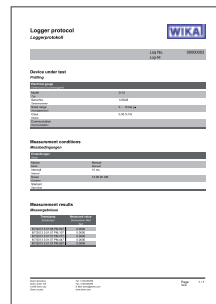



## Scope of delivery

- Wally Box III, model CPH7600 (Order no. 14049201)
- Operating instructions
- Test cables
- Calibration hose with 1/8 NPT male thread connections
- Adapter set consisting of:
  - 1/8 NPT female to 1/4 NPT female
  - 1/8 NPT female to 1/4 BSP female
  - 1/8 NPT female to G 1/2 female
- PTFE thread seal tape
- Battery charger
- 3.1 calibration certificate per DIN EN 10204

## Option

- DKD/DAkkS certified accuracy

## Accessories

### Connection adapters

- Various pressure adapters

### Dirt trap

- Dirt trap (Order no. 13477103)

### Connection cables

- RS-232 interface cable (Order no. 14006096)

### Software

- WIKA-CAL calibration software

## Ordering information

To order the described product the given order number is sufficient. Other options require additional specification.

© 2012 WIKA Alexander Wiegand SE & Co. KG, all rights reserved.  
The specifications given in this document represent the state of engineering at the time of publishing.  
We reserve the right to make modifications to the specifications and materials.

